



WALTZ GRAND

OWNER'S MANUAL

Now, as always, speakers form the most important link in a stereo and home theater system. Therefore, they should be positioned and connected with care. It is our hope that the information contained within this manual will help you in setting up your new speakers and provide you with many years of listening pleasure.

Your Vienna Acoustics Team

CABINETS

For WALTZ, the same outstanding veneer wrapping technique as for all our other speakers is used, and the same high grade quality in finish and workmanship is executed.

Just like all the other Vienna Acoustics speakers, WALTZ features massive and inert cabinet construction. Vienna Acoustics cabinets are designed with the latest computer modeling techniques and use a combination of amorphous materials in order to ensure that they are both stiff and well damped. Additionally, our designs feature narrow front baffles in order to promote accurate imaging. The combination of precise construction using furniture grade finishing techniques and complex internal damping produce designs capable of accurately rendering music.

CONNECTIONS

All connections must be complete and secure, since poor contact between speaker cable and input connector can lead to degradation of sound quality. It is also a good idea to make a point of regularly cleaning all connections in your system since oxidation will build up on a regular basis.

For WALTZ we use 4 mm banana connectors which do not oxidize, but contaminants or surface build-up on your speaker cables and connectors may degrade sound quality. The speaker comes with a set of two banana plugs in which the wire is inserted and held in place by screwing down the insert post. WALTZ offers two possibilities of input sockets, necessitated by the options of parallel and angled wall mounting. Both input possibilities are connected in parallel, which means, it does not matter which one you use, just do not use both inputs at one time.

CABLING

We encourage and recommend the use of high quality speaker cables and believe them to be an important tool for the enthusiast in obtaining maximum enjoyment from their music reproduction system. High quality cabling is a significant tool in the fine-tuning of any audio system.

As with any purchase, listen carefully and allow your ears to guide you.

It is beyond the scope of this manual to provide a useful compendium concerning cables, or to make specific brand or model recommendations. A number of high quality magazines do in fact list cable recommendations.

AMPLIFICATION

Our speakers demonstrate outstanding sonic results with a variety of amplifier types. They feature a combination of high efficiency and gentle impedance curves that allow them to be used with either solid state or tube electronics.

However, it is still important to select an amplifier with care since the full potential of your system will only be revealed by quality electronics. Amplifier designs do have distinct and different sounds.

It is important to listen carefully to the match of amplifier and loudspeaker to ensure that the combination works well sonically for you.

Though rated amplifier wattage bears little correlation to either sound quality or drive capability, the user is cautioned that amplifiers of low wattage ratings, when stressed beyond their limits will produce audible amounts of distortion.

This distortion can and will damage loudspeaker components and will not be covered by warranty.

BURNING IN OR BREAKING IN NEW LOUDSPEAKERS

Your loudspeakers contain a large number of precision built moving parts. These parts require playing time initially to develop their maximum smoothness and extension.

Very audible improvements can be observed during about 30 hours of playing. Additional improvements will be evident after 100 hours of playing time, at which point the speakers have reached their full musical potential.

POSITIONING

Room acoustics and positioning of a speaker within the room have an important effect on sound quality.

WALTZ offers the possibility of beautiful integration in any living room without taking away space. This is made possible without compromising sound quality, because WALTZ has been designed and developed for placement close to the wall, factoring in the influences on the sound of the speaker that this positioning will have.

The strikingly angled walls of the cabinet provide lots of mounting placement options:

1. OnWall application:

8 positions:

4 x 90 degrees, and in each of the 4 positions is the possibility to angle WALTZ towards or away from the listener, or parallel to the wall.

2. Stand alone application, for placing on top of a TV or in a bookshelf.

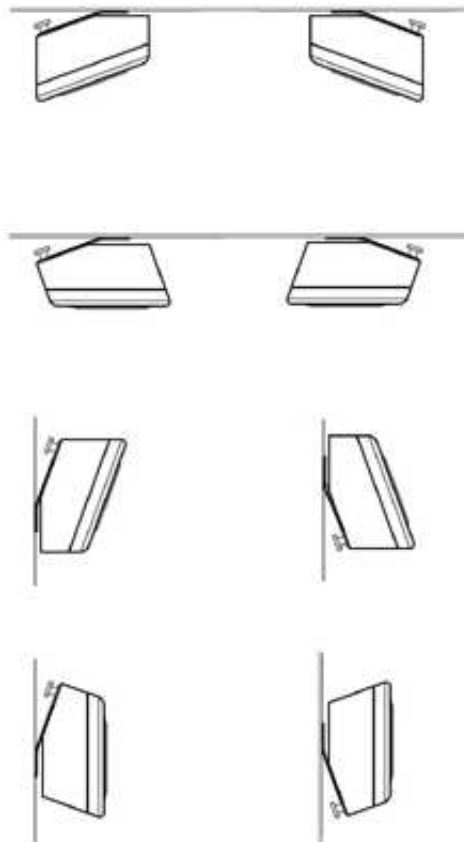

ACCESSORIES IN PAPER BOX

Wall mounting device: 1 pc.
for on-wall application.

Knurled screws: 2 pcs.
for connecting the cabinet with the wall mounting device.

Banana plugs: 2 pcs.
for connecting the speaker cables.

Teethed washer: 2 pcs.
must be used to prevent loosening of the knurled screws.

American wall mounting screws plus wall mounting anchors: 2 pcs.

European wall mounting screws plus wall mounting anchors: 2 pcs.

Transparent rubber feet: 4 pcs.
for stand alone application only!
for protection of the cabinet-bottom, if not wall mounting.

MOUNTING

→After placing the wall-mounting anchor into the wall, fix the wall-mounting device with the wall mounting screws.

ATTENTION:

Use the inner, longer hole of the wall-mounting device for vertical positioning.

Use the outer, round hole just for center position (horizontal positioning).

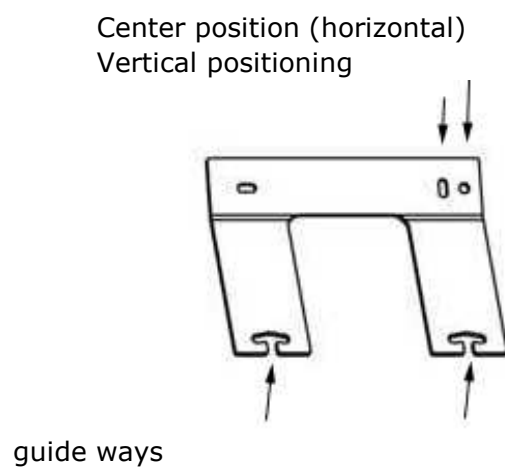

→Put the teethed washer on the knurled screws.

ATTENTION:

The teathed washers are very important to prevent loosening of the knurled screws.

→Position the knurled screws halfway into the inserts of the cabinet.

→Now you can put the speaker into the guide ways of the wall-mounting device and tighten the knurled screws strongly.

ATTENTION:

Please make sure that the teathed washer sticks between the knurled screw and the wall-mounting device.

Please make sure, that the knurled screws securely snap into the right position.

- 1** Knurled screws
- 2** Teeth washers
- 3** Wall mounting device

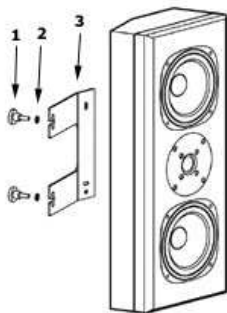

ATTENTION:

For safety reasons it is necessary to check the knurled screws, which fix the speaker to the wall-mounting device, twice a year.

Keeping the speaker secure depends:

1. on the force you are able to apply on the screw
2. on the correct positioning of the teeth washer: between the knurled screw and the black wall-mounting device.

ROOM TREATMENT

Good sounding rooms have a well-balanced acoustic. This does not mean that your home should look like a recording studio.

Commonly found furnishings such as book-shelves, carpeting and furniture all exhibit beneficial amounts of absorption and dispersion. Rooms with little furniture, carpeting or other surfaces will demonstrate poor damping and will produce a hard, bright sound.

For WALTZ we recommend to test a few positions, because it can make a huge difference in sound, where the speaker is attached to the wall. Some places can produce excess or insufficient bass. A difference of only 30 cm can allow for superior performance.

It is also recommended, that the area around your speakers is uncluttered, allowing for unobstructed dispersion of the audio signal.

MAINTENANCE

Your speaker cabinets can be cleaned periodically with a soft, damp cloth. It is not necessary to wax them. Please keep them out of direct sunlight and heat, since the colour of the veneer could fade. Should the bass drivers become dusty, it is safe to use a soft brush to clean the woofers.

Under NO circumstances you should attempt to clean dust from the tweeter. Doing so will damage the delicate silk domes.

Happy Listening!

Your Vienna Acoustics Team